

IC100-5 Crawler Carrier



PAYLOAD

22,050 LBS

OUTPUT RATING

256 HP

TRANSPORT WEIGHT

25,507 LBS

KATO

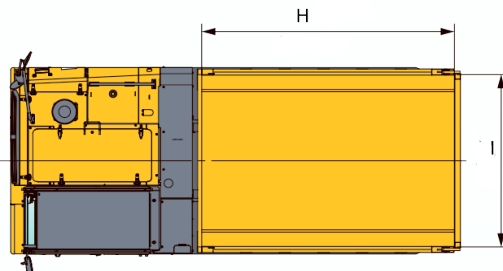
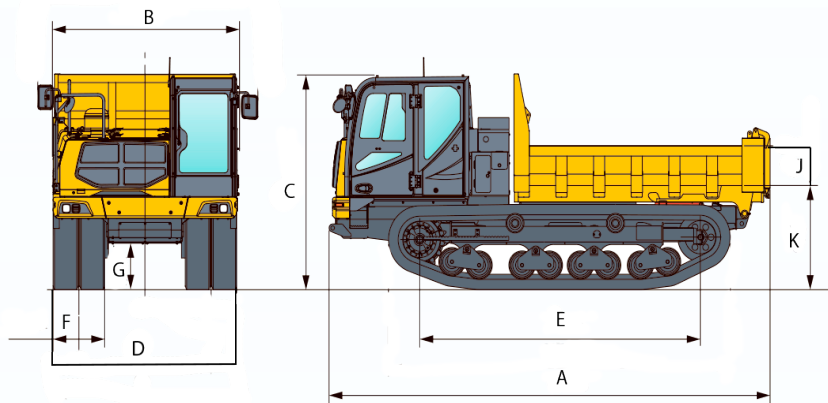

IC100-5 Crawler Carrier Working Ranges

A.	Overall length	19'7"
B.	Overall width	9'9"
C.	Overall height	8'10"
D.	Overall crawler width	8'4"
E.	Tumbler center distance	12'5"
F.	Crawler track width	2'4"
G.	Minimum ground clearance	1'11"
H.	Vessel length	10'10"
I.	Inner vessel width	7'6"
J.	Vessel height	19.5"
K.	Vessel floor height from ground	4'4"
L.	Max dump height	14'8"

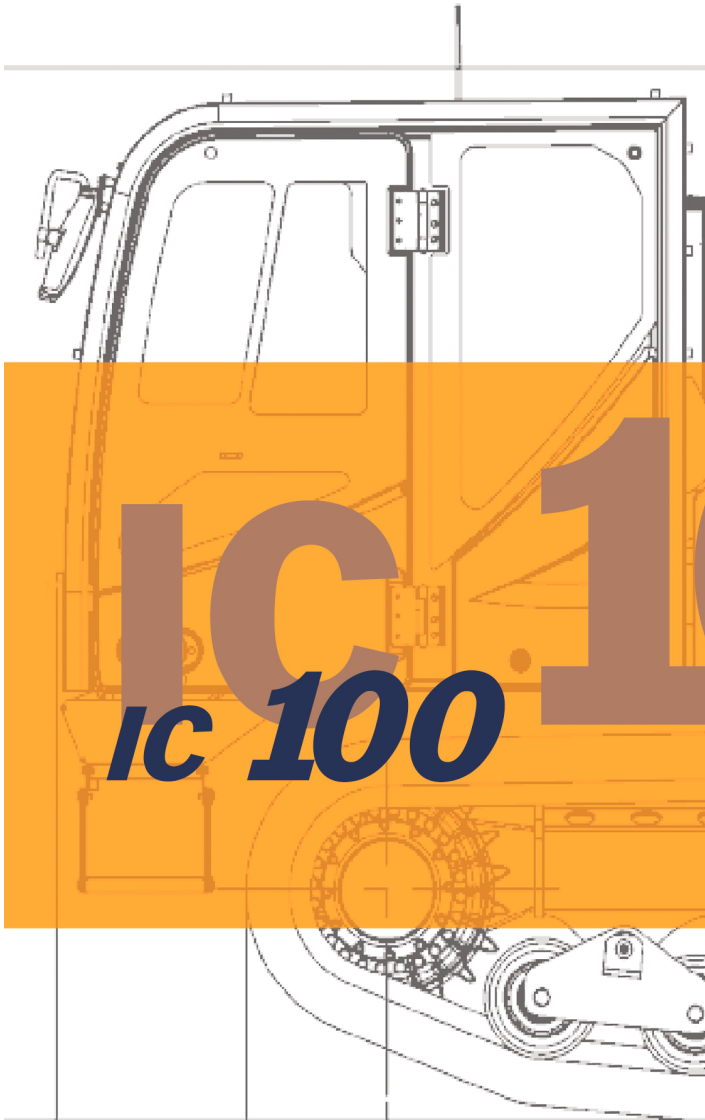

MODEL	IC100
Performance	
Transport Weight	25,507 lbs
Payload	22,050 lbs
Ground Pressure (Empty/ Loaded)	4.05 psi/ 7.56 psi
Travel Speed (Low/High)	5.0/7.5 MPH
Gradeability	20 Degrees
Engine	
Model	Cummins B6.7
Rated Output	256 HP
Fuel Tank Capacity	82.4 Gallons
Def Tank Capacity	12.3 Gallons
Vessel	
Leveled	4.8 yards ³
Heaped	7.3 yards ³
Dimensions LxWxH	10'10" x 7'6" x 1'7"
Style	Boat-shaped rear opening vessel
Maximum Dump Angle	65°



www.KATOCES.com

400 Production Court

Elizabethtown, KY 42701

(800) 538-1447 | Fax: (270) 737-0419